

VCS[®] Data Sheet

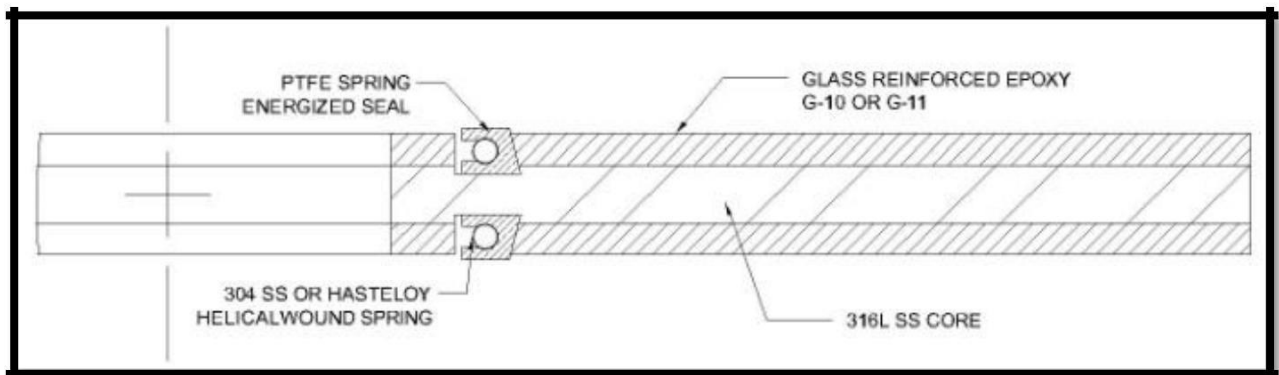

Gasket Properties*

Carrier: NEMA Grade G10/ 316L stainless steel core
Color: Black
Fluid Services: Oil and Gas
Maximum Operating Temperature (°F/°C): 302°F/150°C
Minimum Operating Temperature: (minus): -200°F
Maximum Pressure Class: ASME 2,500#/API 10,000

Typical Physical Properties*

Water Absorption (%): ASTM .01-.02 Typical

NEMA Grade G10 Mechanical Properties*

Tensile Strength (PSI): 41,000

(ASTM D638)

Flexural Strength (PSI): 57,700

(ASTM D790)

Flexural Modulus (Kpsi) LW/CW: 2,900/ 2,600

(ASTM D790)

Compressive Strength (PSI): 65,000

Thermal Properties*

Coefficient of Linear Thermal

Expansion (thickness tested .125") X-axis / Y-axis: 10.0 /

13.0 (IPC-TM 650-2.4.24)

Flammability Rating: Fire retardant

Electrical Properties*

Dielectric Strength (V/mil): 800

Isolation Kit Options:

Seal Types: Teflon (PTFE), Viton, EDPM

Sleeves: G10, Mylar

Washers: G10, ZPS, Stainless Steel

GRE Options: G10, G11, G10 Cryogenic

Carrier Options: 316LSS, 625/825 Inconel, SMO 254, AL6XN, Xeron 100, Duplex/Super Duplex

* Blue type indicates standard material.

Notes:

This is a general guide and should not be the sole means of selecting or rejecting this material. * Values do not constitute specification Limits

¹See GPT chemical resistance guide.

²All isolation products are affected by exposure to heat and moisture where electrical isolation is concerned. Please note that field values may vary from test values due to exposure to one or both of these environmental factors.